



## Combination air valve for sewage Mod. SCF

SCF air valve guarantees the proper operation of sewage lines allowing the entrance and the discharge of large volumes of air, both during pipe draining and filling operations, and the release of air pockets during working conditions.



### Technical features and benefits

- Large lower body designed with strongly sloped high walls to avoid deposit of grease and/or other material, and containing four ribs obtained by casting to guide the stainless steel float.
- Upper body containing an air release device protection cup against projections during rapid filling phases.
- Mobile block including a large AISI 316 stainless steel float, placed on the lower body, and connected through a stainless steel rod to the air release system.
- Flat obturator in solid polypropylene to avoid deformations and to prevent it from remaining stuck to the gaskets, while other materials have the tendency to do it.
- Drainage valve for chamber control and draining.
- Nozzle and gasket holder (pat. pending) wear resistant thanks to gasket compression control
- Maintenance can be easily performed from the top without removing the air valve from the pipe.
- Evacuation bend in polypropylene standard for DN 50/65 and on request for other DN.

### Applications

- Sewage main transmission lines.
- Treatment plants.
- Irrigation systems in presence of solids/debris in suspension.
- Whenever the technology of air valves for treated water can't be used for the risk of clogging and damages to the internal components.

## Operating principle

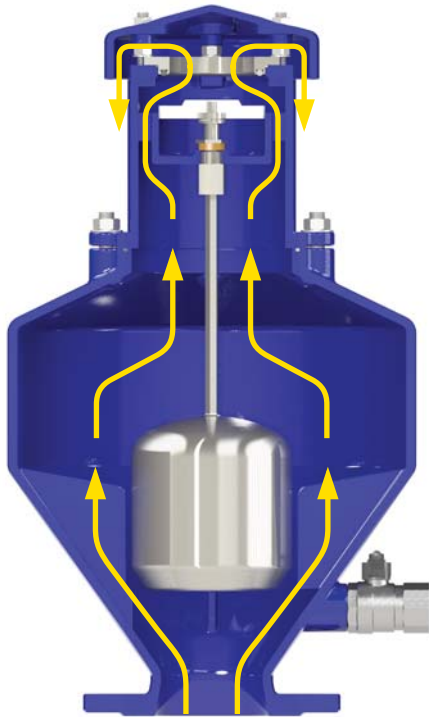

### Discharge of large volumes of air

During the pipe filling it is necessary to discharge air as water flows in. The SCF, thanks to an aerodynamic full port body and deflector, will make sure to avoid premature closures of the mobile block during this phase.

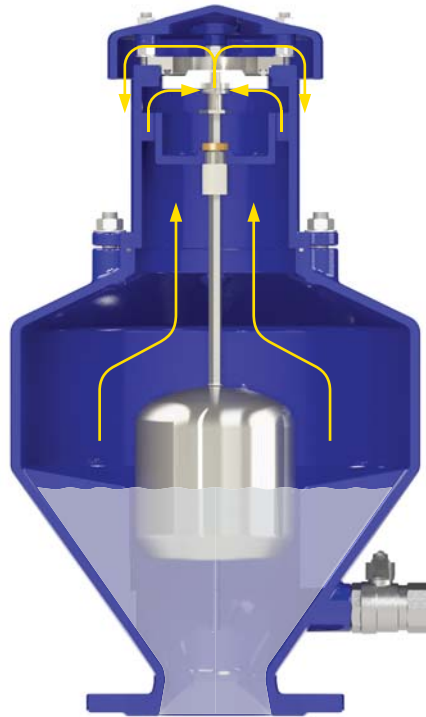

### Air release during working conditions

During operation the air produced by the pipeline is accumulated in the upper part. Little by little it is compressed and its volume increases, pushing the liquid level downwards allowing the air release through the nozzle.

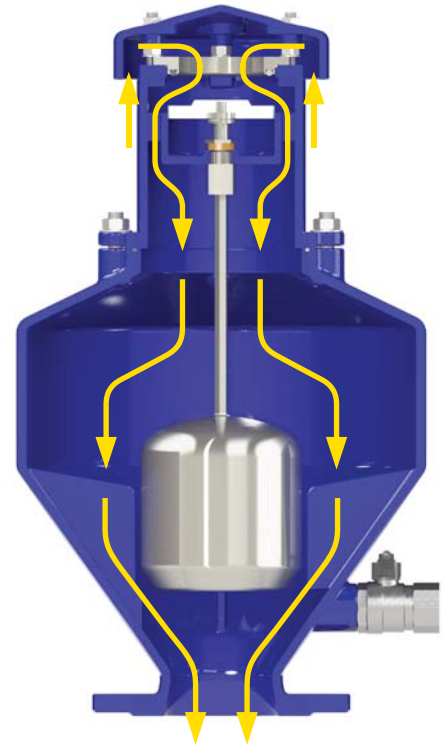

### Entrance of large volumes of air

During pipeline draining, or pipe bursts, it is necessary to bring in as much air as the quantity of outflowing water. This is to avoid negative pressure and serious damages of the pipeline and the entire system.

## Optional



■ **Vacuum breaker version Mod. SCF 2F**, to allow the entrance and discharge of large volumes of air only. This model is normally recommended in changes in slope ascending, long ascending segments, and wherever the air release won't be required.



■ **Version for submerged applications, SUB series**, available both for SCF and SCF 2F Models, with elbow for air conveyance. The design sprang from the necessity of having an air valve performing also in case of flood, without the risk of contaminated water entering the pipeline. Another benefit of SUB is to avoid the spray effect, conveying spurts coming from the rapid closure of the air valve.



■ **Version for air discharge only SCF EO series (on request)**, available both for SCF and SCF-2F models. The most important application of EO is to allow the air valve installation in those locations of the system where HGL may drop below the pipe profile, and to any other node where for project requirements air entrance must be avoided.

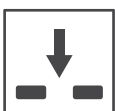

■ **Version for air entrance only SCF IO series**, available for vacuum breaker model only. The most important application of IO is to allow the air valve installation in those locations of the system where, for project requirements, air discharge and release must be avoided.

## Air flow performance charts

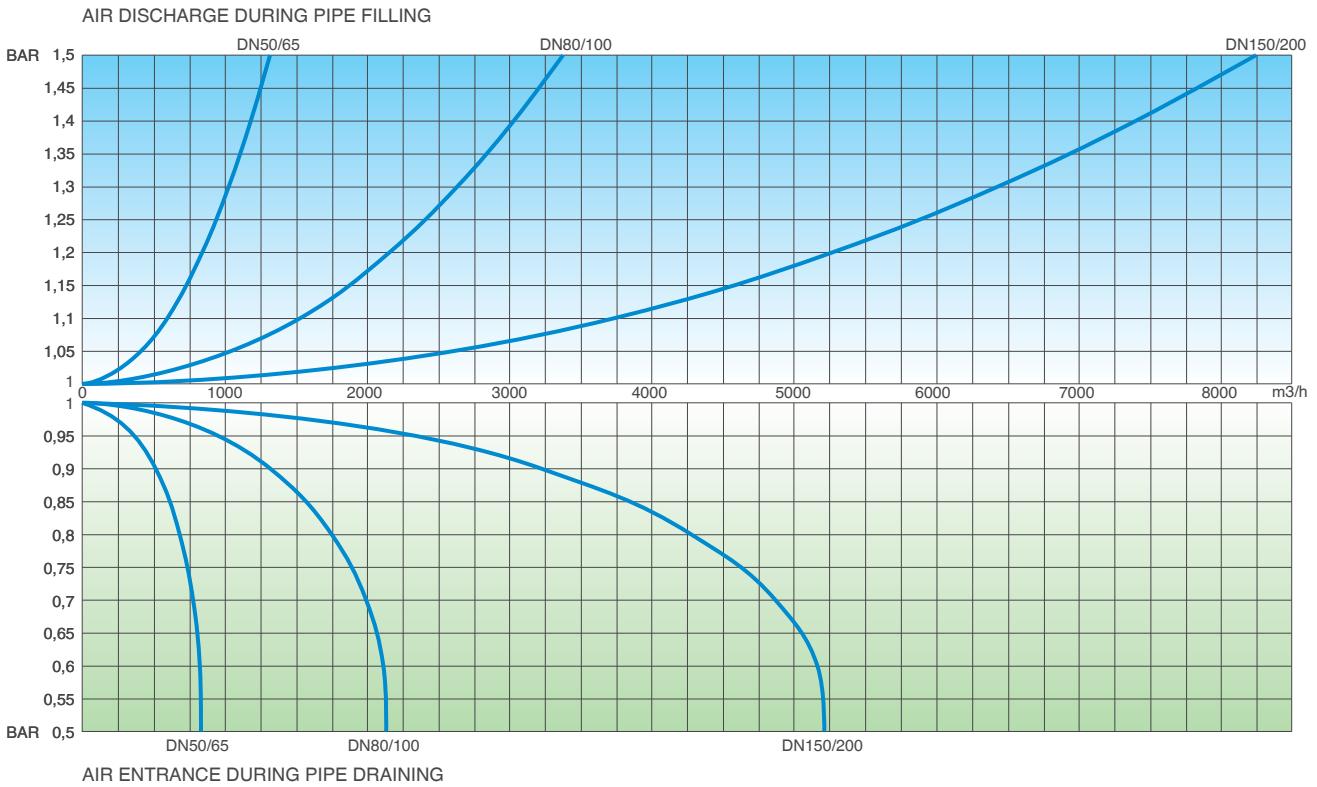

### Working conditions

- Waste water 70° C max.;
- Maximum pressure 16 bar;
- Minimum pressure 0,3 bar;
- Lower pressure version on request.

### Standard

- Designed in compliance with EN-1074/4 and AWWA C-512.
- Flanges according to EN 1092/2.
- Epoxy painting applied through fluidized bed technology blue RAL 5005.
- Changes and variations on the flanges and painting details available on request.

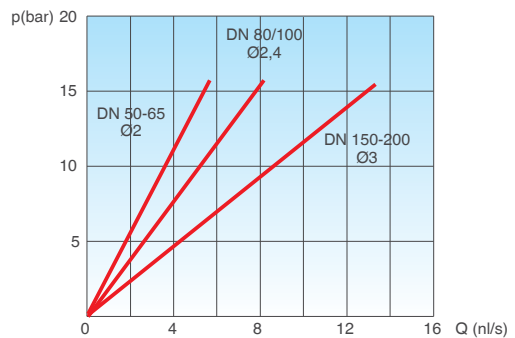

AIR RELEASE DURING WORKING CONDITIONS

DN mm	A mm	B mm	C mm	D mm	Weight Kg
50/65	185	550	300	202	29
80/100	220	600	350	190	40
150	285	850	488	243	78
200	340	850	488	243	82

The dimension B doesn't include the evacuation bend.

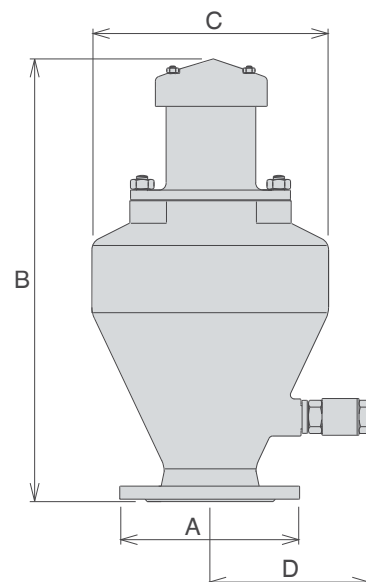

## Technical details

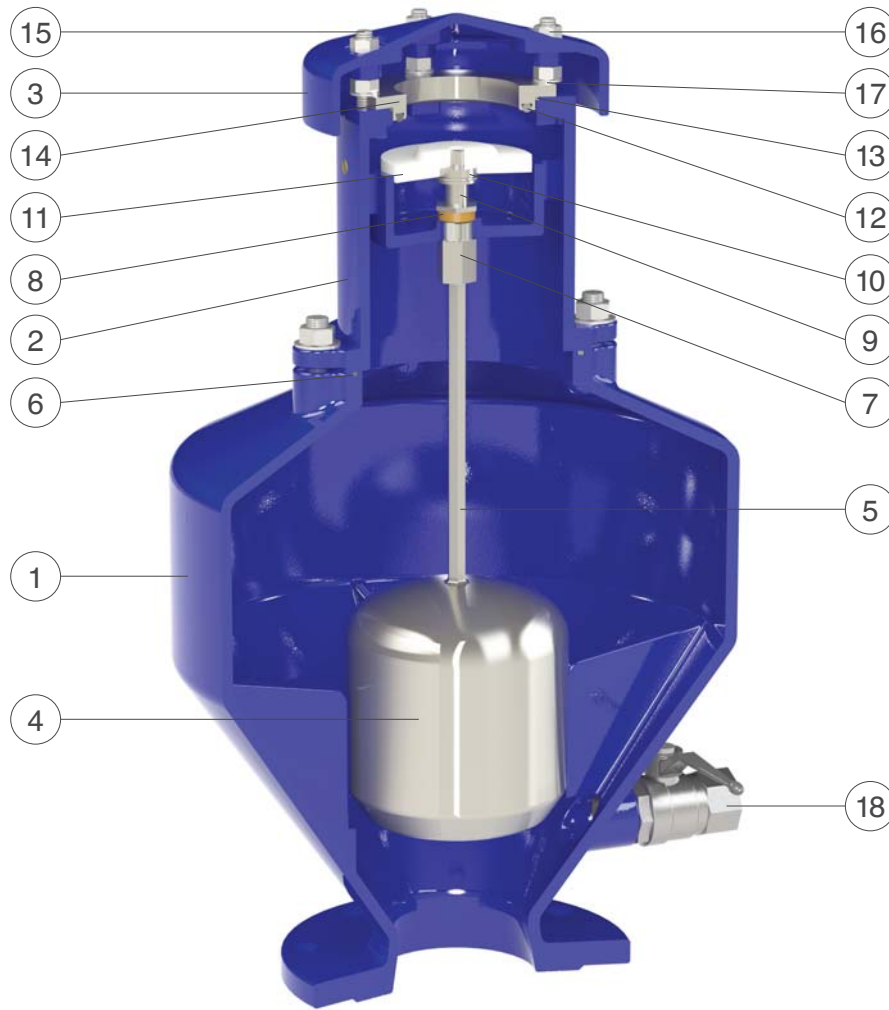

N.	Component	Material	Standard
1	Lower body	ductile cast iron	GJS 500-7
2	Upper body	ductile cast iron	GJS 500-7
3	Cap	ductile cast iron	GJS 500-7
4	Float	stainless steel	AISI 316
5	Float shaft	stainless steel	AISI 316
6	O-ring	NBR	
7	Driving sleeve	stainless steel	AISI 316
8	Plane gasket	NBR/polyurethane	
9	Gasket holder	stainless steel	AISI 316
10	Nozzle subset	stainless steel	AISI 316
11	Obturator flat	polypropylene	
12	Seat gasket	NBR	
13	O-ring	NBR	
14	Seat	stainless steel	AISI 316
15	Studs	stainless steel	A2/A4/AISI 316
16	Nuts	stainless steel	A2/A4/AISI 316
17	Washers	stainless steel	A2/A4/AISI 316
18	Ball valve 1"	stainless steel	AISI 316